

VALVOLINE PROFESSIONAL SERIES
SERVICE GUIDE



VALVOLINE PROFESSIONAL SERIES

We Do It All

COMPLETE AUTOMOTIVE SYSTEM

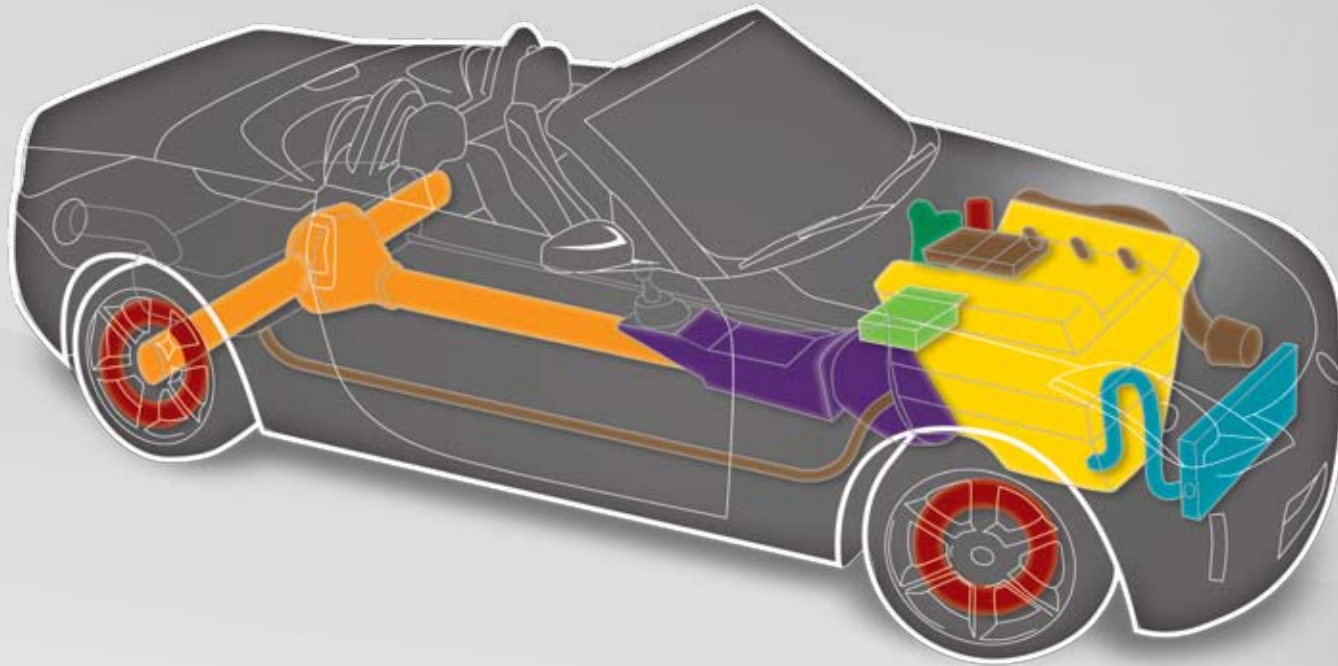

VPS Service Plus Program *Free Protection up to 210,000 miles or 8 model years!*

3 levels of odometer-based enrollment plans

	Level 1	Level 2	Level 3
Enrollment	• 0 to 36,000 miles	• 36,001 to 50,000 miles	• 50,001 to 75,000 miles
Term:	• 210,000 miles or 8 model years	• 210,000 miles or 8 model years	• 1 year or 15,000 miles
Coverage:	• Up to \$4,000	• Up to \$2,000	• Up to \$500



Covered Services:	Service Interval to continue protection
Engine Additive	5,000 mi
Engine Cleaning.....	15,000 mi
Fuel System Service (including Diesels).....	15,000 mi
Automatic Transmission Service.....	30,000 mi
Manual Transmission Service	30,000 mi
Transfer Case / Transaxles.....	30,000 mi
Differential / Gear Box Service (Front and/or Rear).....	30,000 mi
Cooling System Service.....	30,000 mi
Power Steering Service	30,000 mi

There is a 500 mile grace period to allow for flexibility in scheduling these maintenance services in order to maintain coverage.

No sign-up necessary – if a problem occurs simply call our toll-free number 1.877.VPS.1247 prior to having any repairs made and report the incident, and we will work with you to attain a statement of damage with an itemized cost of repair and invoices from the initial service to date. We will begin the claim process immediately.

Coverage remains with vehicle and is transferable as long as the schedule maintenance is maintained using Valvoline Professional Series Products.

Automatic Transmission Service



Problem:

- 90% of automatic transmission failures are due to overheating and fluid contamination.
- Conventional transmission service removes only half of the contaminated fluid.
- Leftover fluid contaminates the new fluid and causing new deposits to form more quickly.

What We Do:

- Add and circulate VPS Transmission Cleaner to remove deposits & debris from the transmission system.
- New Valvoline Automatic Transmission Fluid will be added to your transmission.
- VPS Transmission Conditioner is added to protect against shudder and premature wear while conditioning seals to prevent leaks.

Benefit:

Helps maintain proper shifting characteristics and prolong the life of your transmission.

Transmission With Deposits



Clean Transmission



You may qualify for free protection up to 210,000 miles and \$4,000 for this service. No sign-up necessary – ask your Service Manager for details.

Cooling System Service



Problem:

- Cooling system failure is the leading cause of roadside mechanical breakdowns (US DOT).
- Antifreeze/coolant gradually loses its protective qualities, allowing corrosion and deposits to form.
- This build-up chokes off the proper flow of the coolant and may lead to overheating, breakdown and costly repairs.

What We Do:

- Add and circulate VPS Radiator Super Cleaner throughout the entire cooling system to remove deposits, scale, and corrosion that cause overheating.
- Fortify coolant with VPS Water Pump Lubricant and Protector to increase cooling efficiency and to reduce wear and corrosion.
- Top off with VPS Radiator Super Sealer to maintain optimal coolant pressure and prevent minor leaks.

Benefit:

Helps extend the life of cooling system components, keeps the entire system clean, and functioning as efficiently as possible.

You may qualify for free protection up to 210,000 miles and \$4,000 for this service. No sign-up necessary – ask your Service Manager for details.

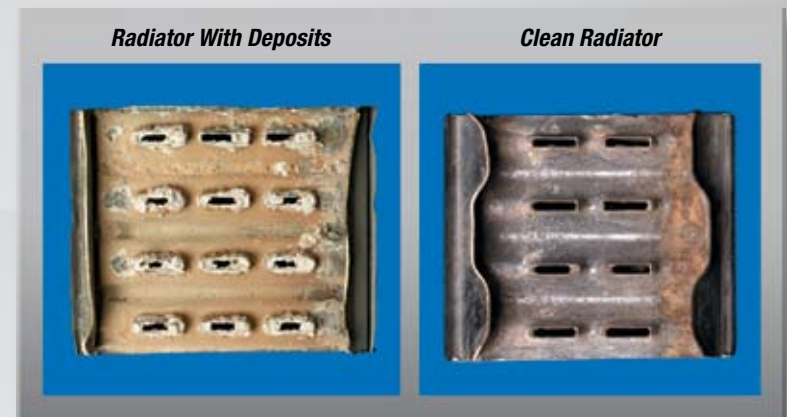

Fuel System Service



Problem:

- Fuel system deposits rob your vehicle of gas mileage and acceleration while increasing harmful emissions.
- Deposits are a by-product of the combustion process and need to be removed on a regular basis to maintain proper operation of your engine.

What We Do:

- Attach cleaning tools to the fuel system to remove deposits from fuel injectors to improve fuel spray pattern and engine efficiency.
- Remove deposit build-up from the intake valves and combustion chambers.
- Thoroughly clean the entire air intake system including the throttle body and intake manifold to improve throttle response and reduce hesitation.

Benefit:

Helps to improve fuel economy, smoother idle and acceleration, and reduces emissions.

You may qualify for free protection up to 210,000 miles and \$4,000 for this service. No sign-up necessary – ask your Service Manager for details.

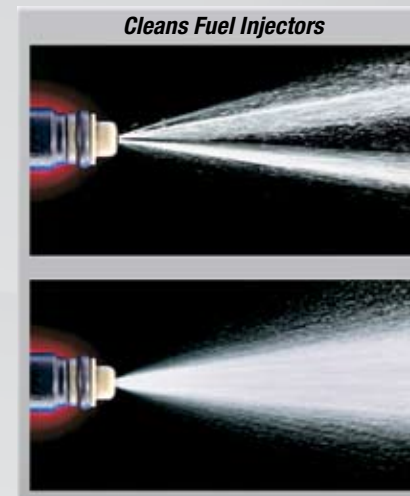

Solvent-Free Complete Oil System Service



Problem:

- Up to a half quart of used oil and sludge remain in your engine after a traditional oil change.
- Sludge and contaminants lead to mechanical breakdowns, premature engine failure, and costly repairs which may exceed \$5,000.

What We Do:

- Drain the used oil from your vehicle and replace the oil filter.
- Add and circulate the cleaner throughout your entire engine dissolving and removing sludge and other contaminants.
- Drain the cleaner containing the dissolved contaminants, change the oil filter once more, and add your choice of Valvoline Motor Oil.

Benefit:

Helps prolong the life of the engine, increase fuel economy and improve engine performance.

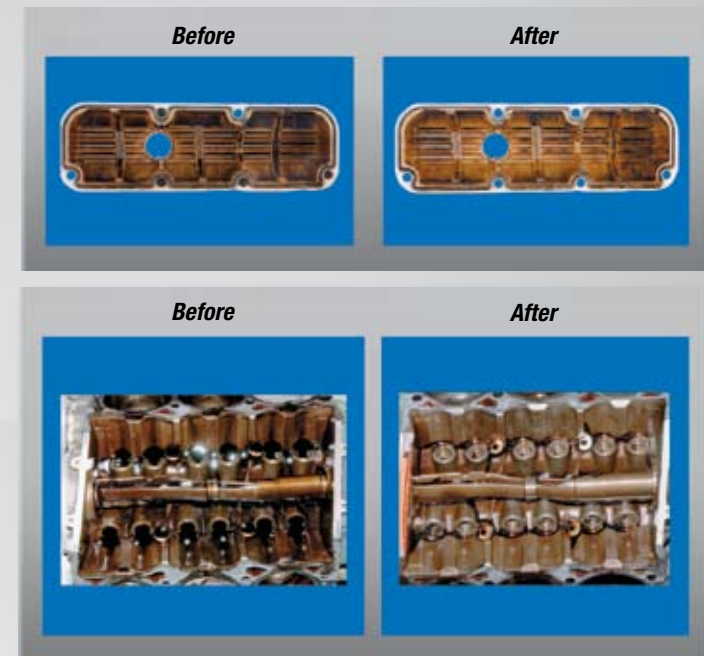

You may qualify for free protection up to 210,000 miles and \$4,000 for this service. No sign-up necessary – ask your Service Manager for details.

Power Steering Service



Problem:

- Power steering fluid is one of the most commonly neglected fluids in a vehicle – frequently used well beyond its usable life.
- Extreme heat and pressure from everyday driving breaks down its performance, leading to increased wear in the pumps, valves, and gears.
- Increased wear risks expensive steering system failures, which may easily exceed \$1,000 in costs.

What We Do:

- Remove the old, contaminated fluid from the power steering reservoir.
- Add powerful, yet safe cleaners to the power steering system and circulate repeatedly to effectively remove all contaminated fluid and debris.
- Replace with new synthetic-based VPS Power Steering Fluid to prevent squeals and leaks.

Benefit:

Provides optimal steering efficiency and helps extend the life of the power steering components.

Power Steering Spool Seal Comparison

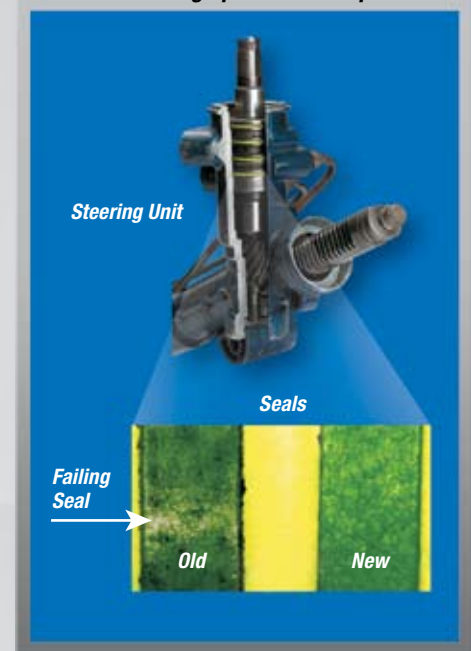

*You may qualify for free protection up to 210,000 miles and \$4,000 for this service.
No sign-up necessary – ask your Service Manager for details.*

Differential / Gear Box Service



Problem:

- Gear oil in the differential or gear box is the most commonly overlooked regular maintenance service.
- Vehicle manufacturer's recommended service intervals start as early as 7,500 to 15,000 miles.
- Replacing the differential assembly may cost as much as \$1,500.

What We Do:

- Evacuate all of the old, contaminated gear oil from the gear box.
- Replace with full synthetic Valvoline gear oil enriched with additives to protect against friction, wear, and corrosion.
- Specially formulated with Limited Slip additive to prevent noise and chatter from the gear box.

Benefit:

Helps increase fuel economy as well as extend the life of the gear box and its components.



You may qualify for free protection up to 210,000 miles and \$4,000 for this service. No sign-up necessary – ask your Service Manager for details.

All Season Heater & A/C Odor Eliminator Service



Problem:

- Mold, mildew, fungi, and bacteria growing inside the dark, damp evaporator of the air conditioning & heating system.
- This can cause the quality of the air you breathe inside your vehicle to degrade up to 5 times worse than outside air.
- These harmful organisms may trigger allergies, asthma symptoms and lung problems for those in the vehicle.

What We Do:

- Inject cleansing foam into the evaporator core of the air conditioning and heating system to eliminate mold, mildew, and other odor causing contaminants.
- The ultra foaming action neutralizes and rids the system of these harmful contaminants as the foam breaks down and liquefies back out of the heating and A/C system.
- Air intake cleaner is sprayed into the ventilation system and onto the cabin air filter to complete the entire cleaning process.

Benefit:

Keeps the air you breathe free from odors and harmful mold and mildew spores.



Anti-Corrosion Battery Service



Problem:

- Corrosive build-up on the battery terminals significantly reduces cranking capacity (difficulty starting) and shortens battery life, which may leave you stranded when you least expect it.

What We Do:

- Cover any existing corrosive elements with VPS Battery Cleaner to neutralize and eliminate the caked on build-up on the terminal posts.
- Remove the battery cables and place a proprietary protector pad around each terminal post to prevent future corrosive build-up for the lifetime of the battery.
- Replace the battery cables over the protector pads and ensure a secure connection.

Benefit:

Helps restore cranking efficiency (easier starts) and extend battery life. Backed by an Anti-Corrosion Lifetime Guarantee.



Anti-corrosion lifetime guarantee: this service will prohibit corrosion for the life of the battery or we will replace the VPS Battery Kit at no cost.

Diesel Fuel System Service



Problem:

- Even minor disruptions in the fuel injector spray pattern can cause a significant decrease in fuel economy and performance.
- Diesel fuel injectors are more prone to efficiency-robbing deposit build-up due to high temperatures directly over the combustion chamber.
- Replacing just one clogged injector may cost you over \$1,000.

What We Do:

- Circulate specially designed cleaners to treat even the toughest deposits, yet completely safe for all diesel systems to restore the diesel fuel system to peak performance.
- Diesel Cleaning Tool administers the powerful cleaners to eliminate the performance robbing contaminants from the fuel injectors and combustion chambers within minutes.
- VPS Diesel Fuel Injector Treatment is added to the fuel tank, which contains:
 - *Cetane improver for increased engine efficiency*
 - *Lubricity additives to lubricate the fuel pump and injectors*
 - *Synthetic cleaners to help prevent future deposit build-up*

Benefit:

Helps improve fuel economy, power and cures hard starts along with rough idle. Also reduces harmful emissions and black smoke.



*You may qualify for free protection up to 210,000 miles and \$4,000 for this service.
No sign-up necessary – ask your Service Manager for details.*

Brake Fluid Service



Problem:

- Over time Brake Fluid absorbs moisture and leads to corrosion within the brake line, leading to sluggish brake response.
- Corrosion can cause premature failure of the brake system components, which can cost over \$1,000 to replace.
- Many vehicle manufacturers are recommending this service every 2 years or 24,000 miles for optimal safety.

What We Do:

- Evacuate all of the old, contaminated brake fluid from the Anti-Lock Brake System (ABS).
- Replace with premium-dry Valvoline Brake Fluid to ensure the least amount of moisture within the brake system.
- Secure Valvoline dust covers over each bleeder valve to prevent clogging and rusting so valves remain intact and do not need replaced.

Benefit:

Valvoline's DOT 4 Brake Fluid helps prevent sluggish brake response even during panic stops, downhill braking, and stop-and-go driving.

Corroded Brake Lines



New Brake Lines



Valvoline's Brake Fluid exceeds the U.S. Department of Transportation specifications for both DOT 3 and DOT 4 brake fluids.